

Length

The urinal is available in five standard lengths: 1200 mm, 1500 mm, 1800 mm, 2100 mm and 2400 mm.

Waste Outlet

All urinals are supplied with a 50 mm (2") BSP dome grated waste fitting positioned centrally

Flushing System

All urinals are fitted with a sparge system concealed within the units' construction. The sparge system connection to the flushpipe is top entry for an exposed surface mounted cistern (see fig 1). By using an elbow fitting the sparge system connection can be easily converted to back entry for a concealed duct mounted cistern.

Flushpipe

Urinals are supplied with 22 mm diameter stainless steel flushpipes and wall fixing clips. The length of each flushpipe allows for its cistern to be mounted at the maximum recommended height.

Cistern

All urinals are supplied with plastic or optional stainless steel automatic flushing cisterns. Each cistern is complete with lid, syphon and petcock. The recommended mounting height is 1800 mm minimum and 2000 mm maximum from the underside of the cistern to finished floor level.

Cistern Capacity

Urinal length	-1200 mm-1500-2400 mm
Cisterns	-1 x 9.0 litre -1 x 13.65 litre

1. Base product code

- 064 wall hung trough urinal

2. Length

- 1200 -2100
 -1500 -2400
 -1800

3. Outlet (as facing)

- C -central

4. Flushing System

- TE -Top Entry

5. Options

- 131 -stainless steel cistern
 -WG -White **Enviro-Glaze**
 (other colours please specify _____)

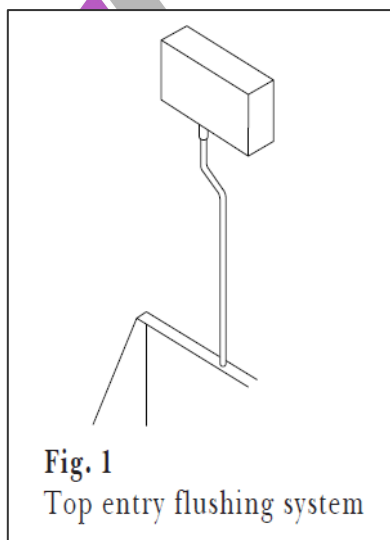

As improvements in the design and performance of Acorn Powell Limited products is continuous specifications may be subject to change without notification