

Special Features

- ▲ VANDAL RESISTANT DESIGN
- ▲ HYGIENIC ONE PIECE CONSTRUCTION
- ▲ INTEGRAL RETURN ENDS FOR WALL OR FREE STANDING INSTALLATIONS
- ▲ REMOVABLE ACCESS PANEL WITH TOE RECESS
- ▲ CONCEALED SPARGE PIPES
- ▲ COMPLETE WITH FLUSHPIPE AND CISTERN
- ▲ EASILY AND QUICKLY INSTALLED

Description

The slab urinal has a raised channel to allow drainage pipework to be installed above floor level. The pipework is concealed behind a full width removable access panel which is incorporated into the front of the urinal. The panel, which is angled to provide a toe recess, is held in position by security type screws. The product is available in a range of standard and special lengths.



Construction

The urinal is manufactured in one piece without joints or crevices from grade 304 stainless steel, with all exposed surfaces polished to a satin finish.

The requisite fall to either a right hand or left hand outlet is built into the channel and the back of the urinal is designed to ensure an efficient spread of flushing water without drips or splashing. The urinal back panel is sound deadened to eliminate drumming.

The urinal incorporates a full width removable access panel for maintenance of the trap and drainage pipework. The panel is held in position by security type screws and is angled to provide a toe recess.

Available in either four standard lengths or special lengths, all urinals incorporate concealed sparge pipes and integral return ends for either wall or free standing installations.

Each urinal is supplied with a dome grated waste fitting and either one or two automatic cisterns and flushpipes.

Options

- ▲ Corner infill section for 'L' or 'U' plan assembly.
- ▲ End feed and off centre flushpipe connection.
- ▲ Stainless steel automatic cistern (see catalogue section 1 - product code 131).

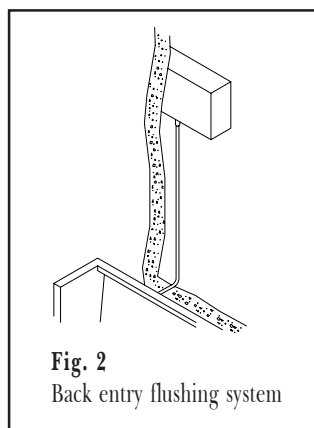
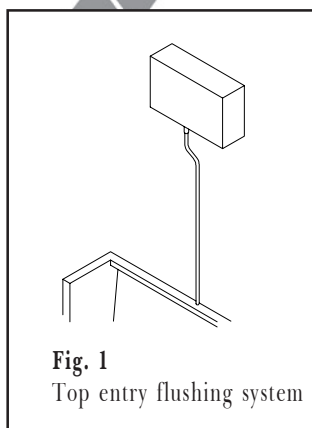
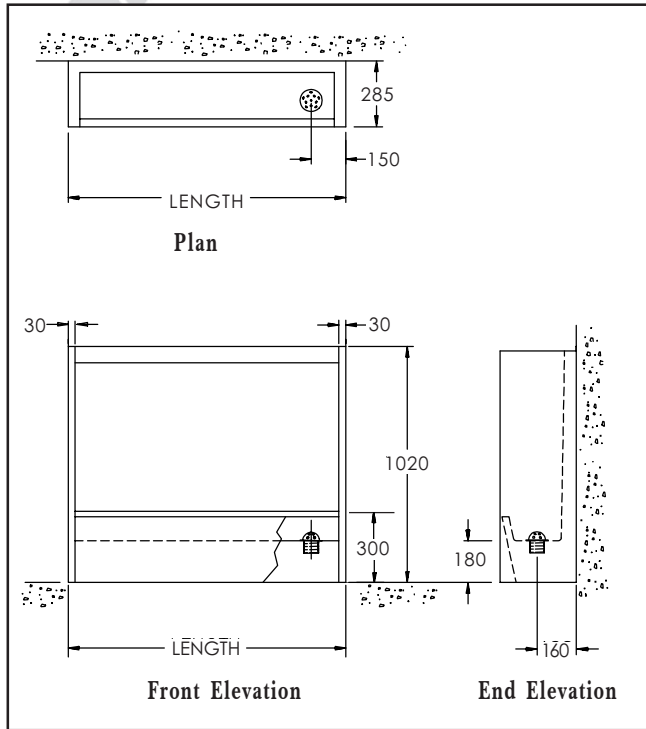

Length

The urinal is available in four standard lengths; 1200 mm, 1800 mm, 2400 mm and 3000 mm. Alternatively any special length up to 3000 mm. Lengths over 3000 mm supplied as multiple units with joint cover trim for abutting ends.

Waste Outlet

All urinals are supplied with a 50 mm (2 in) BSP dome grated waste fitting positioned at either the right hand or left hand end (as viewed facing the unit).

Flushing System

All urinals are fitted with perforated sparge pipes concealed within the units' construction. The sparge pipe connection to the flushpipe can be top entry for an exposed surface mounted cistern (see Fig. 1) or back entry for a concealed duct mounted cistern (see Fig. 2).

Flushpipe

Urinals are supplied with 22 mm diameter stainless steel flushpipes and wall fixing clips. The length of each flushpipe allows for its cistern to be mounted at the maximum recommended height.

Cistern

All urinals are supplied with plastic or optional stainless steel automatic flushing cisterns. Each cistern is complete with lid, syphon and petcock. The recommended mounting height is 1800 mm minimum to 2000 mm maximum from the underside of the cistern to finished floor level.

Cistern Capacity

Urinal Length	-up to 1200 mm	-1201-2400 mm	-2401-3000 mm
Cisterns	-1 x 9.0 litre	-1 x 13.65 litre	-2 x 9.0 litre

Product Code Selection for Order or Quotation

1. Base Product Code

067-floor standing slab urinal

2. Length

-1200 -2400

-1800 -3000

-_____ special (specify)

3. Outlet (as facing)

-R-right hand -L-left hand

4. Flushing System

-TE-top entry -BE-back entry

-S-special (supply dimensioned sketch)

5. Options

-131-stainless steel cistern

-JT-joint cover trim

-CS-corner infill section