

Special Features

- ▲ RESISTANT TO WEAR AND DAMAGE
- ▲ ONE PIECE HYGIENIC CONSTRUCTION
- ▲ EASY TO CLEAN

Description

The squatting WC pan is highly resistant to wear, hygienic and will withstand impact damage. Designed to be installed level with the floor surface, the squatting WC pan is supplied with a back inlet flushing terminal.

Construction

The squatting WC pan is manufactured in one piece without joints or crevices from grade 304 stainless steel, with a matt finish. A back entry flushing terminal, supplied with the WC pan, provides an efficient washdown. Incorporated into the one piece squatting WC pan is an integral vertical waste outlet.

Option

- ▲ Concealed duct mounted high level plastic cistern (see catalogue section 2 - product code code 142).



Technical Specification: Squatting WC Pan

5 Brearley Court, Baird Road, Waterwells Business Park, Quedgeley, Gloucester GL2 2AF Tel: 01452 721211 Fax: 01452 721231 Web: www.acornpowell.co.uk

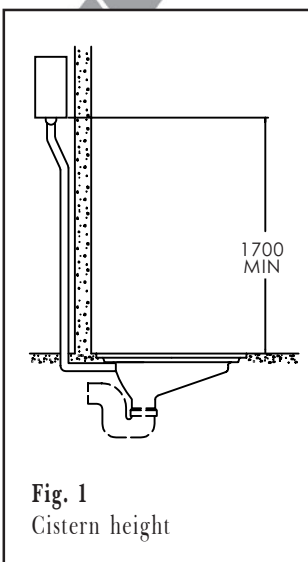
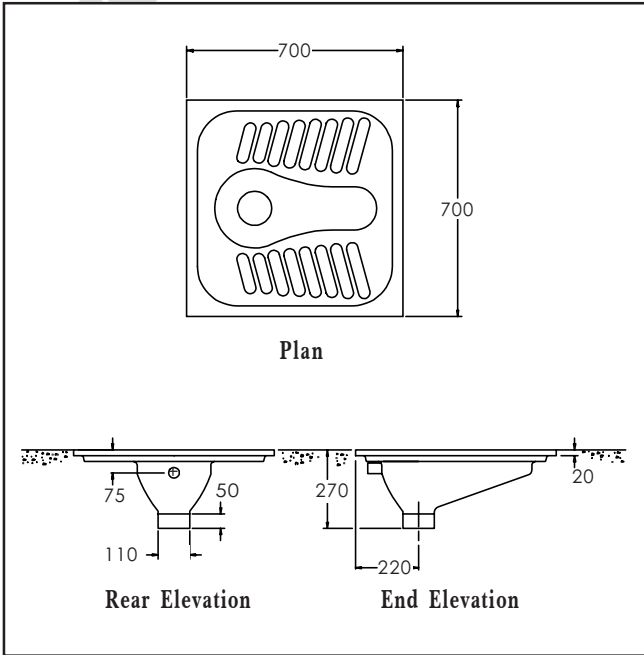

Outlet

The squatting WC pan is manufactured with a 110 mm overall diameter vertical plain outlet.

Inlet

The squatting WC pan is supplied with a back entry flushing terminal suitable for connecting to a 38 mm overall diameter flushpipe.

Cistern and Flushpipe

As an option the squatting WC pan can be supplied with a high level plastic cistern. The plastic cistern is suitable for concealed duct mounting and is supplied with a push button mechanism, syphon, float operated valve and flushpipe.

Cistern Height

To efficiently flush the squatting WC pan the recommended mounting height is 1700 mm minimum from the underside of the cistern to finished floor level (see Fig. 1).

Product Code Selection for Order or Quotation

1. Base Product Code

□112-squatting WC pan

2. Option

□-142HLPB-concealed plastic manual cistern high level with push button mechanism